

# DANVILLE ZONING APPLICATION

FOR ADMINISTRATIVE USE ONLY

APPLICATION# 2024-54    DATE RECEIVED: 8/6/24    FEE PAID: \$ 35 cjk  
8/6/24 1052

DO NOT WRITE ABOVE THIS LINE:

**Step 1: TYPE OF PERMIT REQUESTED AND FEE**

\*Needs to go before Development Review Board

- PERMITTED USE (\$35)                       SUBDIVISION (\$65) \*     DESIGN CONTROL (\$65) \*  
 CONDITIONAL USE (\$65)\*                       VARIANCE (\$65) \*     WAIVER (\$65) \*

**Step 2: ZONING DISTRICT (choose one)**

- MEDIUM DENSITY RESIDENTIAL 1     MEDIUM DENSITY RESIDENTIAL 2     VILLAGE RESIDENTIAL  
 LOW DENSITY RESIDENTIAL     DESIGN CONTROL OVERLAY     HISTORIC NEIGHBORHOODS  
 DEVELOPED SHORELAND OVERLAY     ROUTE 2     CONSERVATION     VILLAGE CORE

**Step 3: APPLICANT/PROPERTY OWNER:** (PLEASE PRINT – if more than one PROPERTY OWNER a separate sheet can be attached)

APPLICANT NAME(S): Dan DeLeo

APPLICANT'S MAILING ADDRESS: 467 Breezy Hill Rd. St. Johnsbury, VT 05819

CONTACT NUMBER: 802-274-9387                      EMAIL: Dannydeleo@gmail.com

*Property Owner Name(s) MUST be the same as recorded on deed. If more than one, separate sheet can be added.*

PROPERTY OWNER NAME(S): Dan DeLeo

PROPERTY OWNER'S MAILING ADDRESS: 467 Breezy Hill Rd. St. Johnsbury, VT 05819

CONTACT NUMBER: 802-274-9387                      EMAIL: Dannydeleo@gmail.com

**Step 4: PHYSICAL LOCATION OF PROJECT PROPERTY (911 ADDRESS):**

596 Pumpkin Hill Rd. Danville, VT 05828

Parcel ID# TH083-006.002                      DEED: BOOK# 177                      PAGE# 254-255

IS PROPERTY ON TOWN WATER AND/OR SEWER?     YES     NO

**Step 5: DESCRIPTION OF PROJECT AND ESTIMATED DATE OF COMPLETION**

Contruction of approximate 1350sf 2 bedroom home completed by summer of 2025

Primary Residence

**Step 6: LOT SIZE & SETBACKS:** (Distance from new construction and lot lines)

LOT SIZE: 3.9 (ACRES)

LOT WIDTH: 740'

FRONT: 650 FT.  
(from center of road)

**SETBACKS**

REAR: 75 FT.

RIGHT SIDE: 150 FT.

LEFT SIDE: 125 FT.

**Step 7: PLEASE ATTACH ONE COPY OF ALL SITE AND PLOT PLANS**

- Copy must include: Site & design of building
- Height of building and landscaping design
- If in Design Control Overlay District: exterior design & exterior materials used

**Step 8: ADJOINING LAND OWNER INFORMATION.** Provide NAME of ALL adjoining landowners. ONLY required if going to a DRB Hearing (Conditional Use, Variance, Subdivision, Waiver, and Design Control Applications)

NAME \_\_\_\_\_

\_\_\_\_\_

\_\_\_\_\_

\_\_\_\_\_

**Step 9: SIGNATURE**

*By signing below, I/We hereby certify that, to the best of my/our knowledge, all of the above is a true representation of the facts related to this proposed project. I/We also hereby request a Hearing before the Development Review Board if application is for a Conditional Use, Variance, Subdivision or Design Control.*

Applicant Dan DeLeo

Date: 6/8/2024

SIGNATURE OF ALL PROPERTY OWNERS REQUIRED (If additional lines required, a separate piece of paper can be added)

Property Owner 

Date: 8/8/24

**FOR ADMINISTRATIVE USE ONLY**

ZONING ADMINISTRATIVE OFFICER ACTION:

APPROVED       DENIED       REFERRED TO DRB (DEVELOPMENT REVIEW BOARD)

\*Note: All applications for CONDITIONAL USE, DESIGN CONTROL, SUBDIVISION, WAIVER and VARIANCE will automatically be DENIED pending a decision by the DRB at a hearing.

ADMINISTRATIVE OFFICER'S SIGNATURE \_\_\_\_\_

DATE \_\_\_\_\_

DATE OF APPROVAL OR DENIAL BY DEVELOPMENT REVIEW BOARD: \_\_\_\_\_

DATE POSTED: \_\_\_\_\_ DATE WARNED: \_\_\_\_\_

HEARING DATE: \_\_\_\_\_ FINAL APPEAL DATE: \_\_\_\_\_

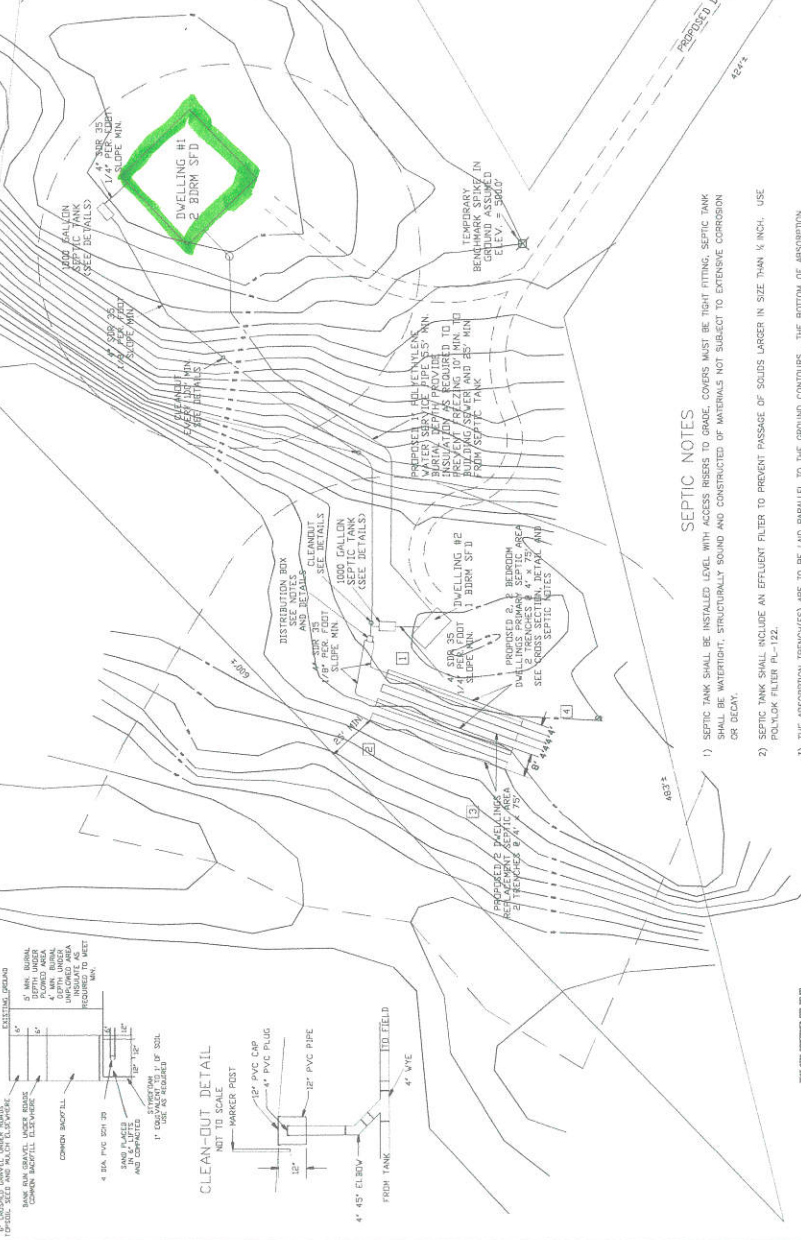
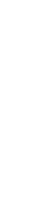
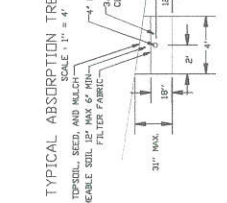
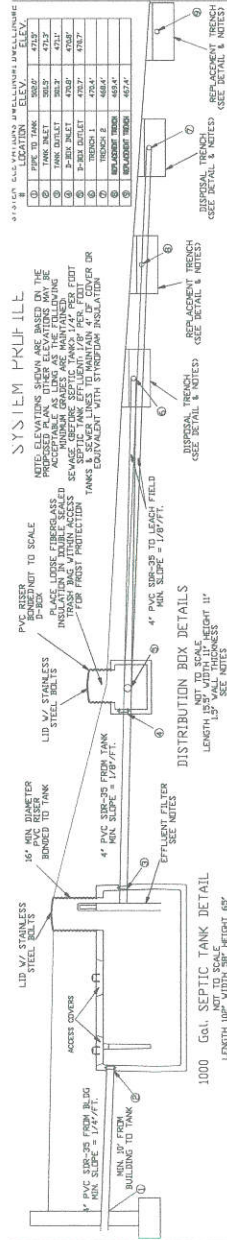

### TEST PIT #1 & 2 SOIL PROFILES

DEPTH	TEXTURE	STRUCTURE	CONSIST.	COLOR	COMMENTS
0'-4"	SANDY LOAM	GR	LOOSE	10R-2/2	NO REACTION TO WATER COLOURS
4'-24"	SANDY LOAM	GR	LOOSE	10R-4/4	
24'-26"	LFS	AK	LOOSE	25T-4/4	NO REACTION TO WATER COLOURS
				25T-4/4	

### TEST PIT #3 & 4 SOIL PROFILES

DEPTH	TEXTURE	STRUCTURE	CONSIST.	COLOR	COMMENTS
0'-4"	SANDY LOAM	GR	LOOSE	10R-2/2	NO REACTION TO WATER COLOURS
4'-24"	SANDY LOAM	GR	LOOSE	10R-4/4	
24'-26"	LFS	AK	LOOSE	25T-4/4	NO REACTION TO WATER COLOURS
				25T-4/4	

**SEPTIC NOTES**

- 1) SEPTIC TANK SHALL BE INSTALLED LEVEL WITH ACCESS RISERS TO GRADE. COVERS MUST BE TIGHT FITTING. SEPTIC TANK SHALL BE WATERTIGHT, STRUCTURALLY SOUND AND CONSTRUCTED OF MATERIALS NOT SUBJECT TO EXTENSIVE CORROSION OR DECA.
- 2) SEPTIC TANK SHALL INCLUDE AN EFFLUENT FILTER TO PREVENT PASSAGE OF SOLIDS LARGER IN SIZE THAN 1/8" INCH. USE POLYCARBONATE (M-122).
- 3) THE ABSORPTION (TRENCHES) ARE TO BE LAID PARALLEL TO THE GROUND CONTOURS. THE BOTTOM OF ABSORPTION TRENCH AND THE DISTRIBUTION PIPING ARE TO BE LEVEL. GRABES TO BE SET WITH AN INSTRUMENT.
- 4) ALL EXTERIOR DOWN LINES SHALL BE 4" RIGID, NON-PERFORATED PIPE. DISTRIBUTION LINES WITHIN THE ABSORPTION TRENCH SHALL BE 4" RIGID, PERFORATED PIPE. END OF THE DISTRIBUTION LINE TO BE CAPPED.
- 5) ALL SEWER AND EFFLUENT DISCHARGE PIPING TO BE SEALED TO ALL TANKS, D-BOXES, ETC. VIA WATER TIGHT SEALS AND / OR DEVICES ALL MATERIALS SHALL MEET THE REQUIREMENTS OF THE WASTEWATER SYSTEM AND POTABLE WATER SUPPLY RULES.
- 6) ALL SYSTEMS TO BE LOCATED ACCURATELY IN THE FIELD. ALL MINIMUM LOCATION DISTANCES OUTLINED IN SUB CHAPTER 9, TITLE 24-S OF THE ENVIRONMENTAL PROTECTION RULES.
- 7) THIS SYSTEM IS TO BE INSPECTED THROUGH THE CRITICAL STAGES OF CONSTRUCTION BY A QUALIFIED CONSULTANT AND IS TO BE MAINTAINED IN ACCORDANCE WITH THE ENVIRONMENTAL PROTECTION RULES.

**DISPOSAL SYSTEM DESIGN**

DESIGN PROPOSED 2 BEDROOM DWELLING & 1 BEDROOM DWELLING

SYSTEM TYPE: SEPTIC TRENCH

AREA REQUIRED: 450 ± 0.7 GAL/SQ FT = 6000 SQ FT

APPLICATION RATE: 0.7 GAL PER SQ FT PER DAY

STONE DEPTH: 12 IN. BELOW PIPE, 18 IN. OVERALL DEPTH

PERCENT OF AREA REQUIRED: 100%

TOTAL AREA REQUIRED: 600 SQ FT

USE 2 TRENCHES @ 4 FT x 75 FT = 600 SQ FT

**POTABLE WATER SUPPLY DESIGN**

1. BEDROOM SHALE (A) DWELLING = 280 GPD TOTAL = 432 GPD
2. BEDROOM SHALE (A) DWELLING = 140 GPD TOTAL = 432 GPD

420 GAL PER DAY DEMAND

RETENTION TIME: 24 HRS

DESIGN FLOW RATE: 18 GPD

DESIGN STORAGE CAPACITY: 432 GPD

DESIGN STORAGE CAPACITY: 432 GPD

DESIGN STORAGE CAPACITY: 432 GPD

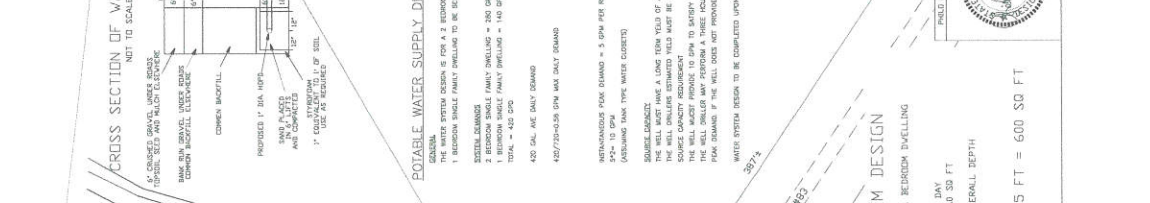

**DANIEL J. DELEO**  
 596 PUMPKIN HILL ROAD, DANVILLE, VT  
**EARTH SURVEYS LLC**  
 133 HAZARD ROAD  
 DANVILLE, VT 05440  
 TEL: 802.342.1122  
 FAX: 802.342.1122  
 SHEET NUMBER: 1 OF 1



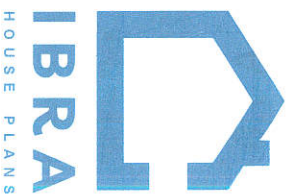

Contact:  
E-mail: [ibrahouseplans@gmail.com](mailto:ibrahouseplans@gmail.com)

Project:  
**MODERN CABIN HOUSE**

General Note:  
1-) THE PLANS ARE COPYRIGHTED BY IBRA HOUSE PLANS LLC, AND INTENDED FOR PERSONAL USE ONLY. NO COMMERCIAL USE OR DISTRIBUTION ALLOWED.  
2-)CONSULT LOCAL AUTHORITIES AND YOUR CONTRACTORS BEFORE CREATING THIS PLAN. THE ENTIRE RESPONSIBILITY FOR THE CONSTRUCTION OF THIS PROJECT IS YOUR AND YOUR CONTRACTOR(S).

Sheet Title:  
**FLOOR PLAN**

Scale:  
**1/4" = 1'-0"**





Sheet No:

**A 0.0**

### SHEET INDEX

- A 0.0 COVER SHEET
- A 1.0 FLOOR PLAN WITH DIMENTIONS
- A 1.1 FRONT-REAR ELEVATION
- A 2.0 RIGHT-LEFT ELEVATION
- A 2.1 SECTION A-A - SECTION B-B
- A 3.0 ROOF PLAN
- A 4.0 ROOF FRAMING PLAN
- A 5.0 FOUNDATION PLAN
- A 6.0 FLOOR FRAMING PLAN
- A 7.0 ELECTRICAL PLAN
- A 8.0 DETAIL DRAWINGS
- A 9.0 WINDOW & DOOR SCHEDULE
- A 10.1 WINDOW & DOOR SCHEDULE
- A 10.2 WINDOW & DOOR SCHEDULE

### SYMBOL LEGEND

-  BUILDING SECTION
-  ELEVATION NAME
-  ROOF SLOPE
-  DOOR TAG
-  WINDOW TAG

### LICENCE & AGREEMENTS

- 1) THE PLANS ARE COPYRIGHTED BY IBRA HOUSE PLANS LLC, AND INTENDED FOR PERSONAL USE ONLY. NO COMMERCIAL USE OR DISTRIBUTION ALLOWED. THIS PLAN CONTAINS DRAWINGS: FLOOR PLAN, 4 ELEVATION, 2 GROSS SECTION, ROOF PLAN, ROOF FRAMING PLAN, FOUNDATION PLAN, FLOOR FRAMING ELECTRICAL PLAN, DETAIL DRAWINGS AND DOOR & WINDOW SCHEDULES.
- 2) CONSULT LOCAL AUTHORITIES AND YOUR CONTRACTORS BEFORE CREATING THIS PLAN. THE ENTIRE RESPONSIBILITY FOR THE CONSTRUCTION OF THIS PROJECT IS YOUR AND YOUR CONTRACTOR(S).
- 3) NOTE: THIS PROJECT IS PRE-MADE DESIGN. IF YOU NEED CUSTOMIZATION OR A NEW PROJECT FOR YOU IBRA HOUSE PLANS ALSO PROVIDES A CUSTOM HOUSE DESIGN SERVICE. THIS SERVICE IS CHARGED FOR ADDITIONAL CHARGES. PLEASE EMAIL US FOR CONTACT.  
E-mail: [ibrahouseplans@gmail.com](mailto:ibrahouseplans@gmail.com)

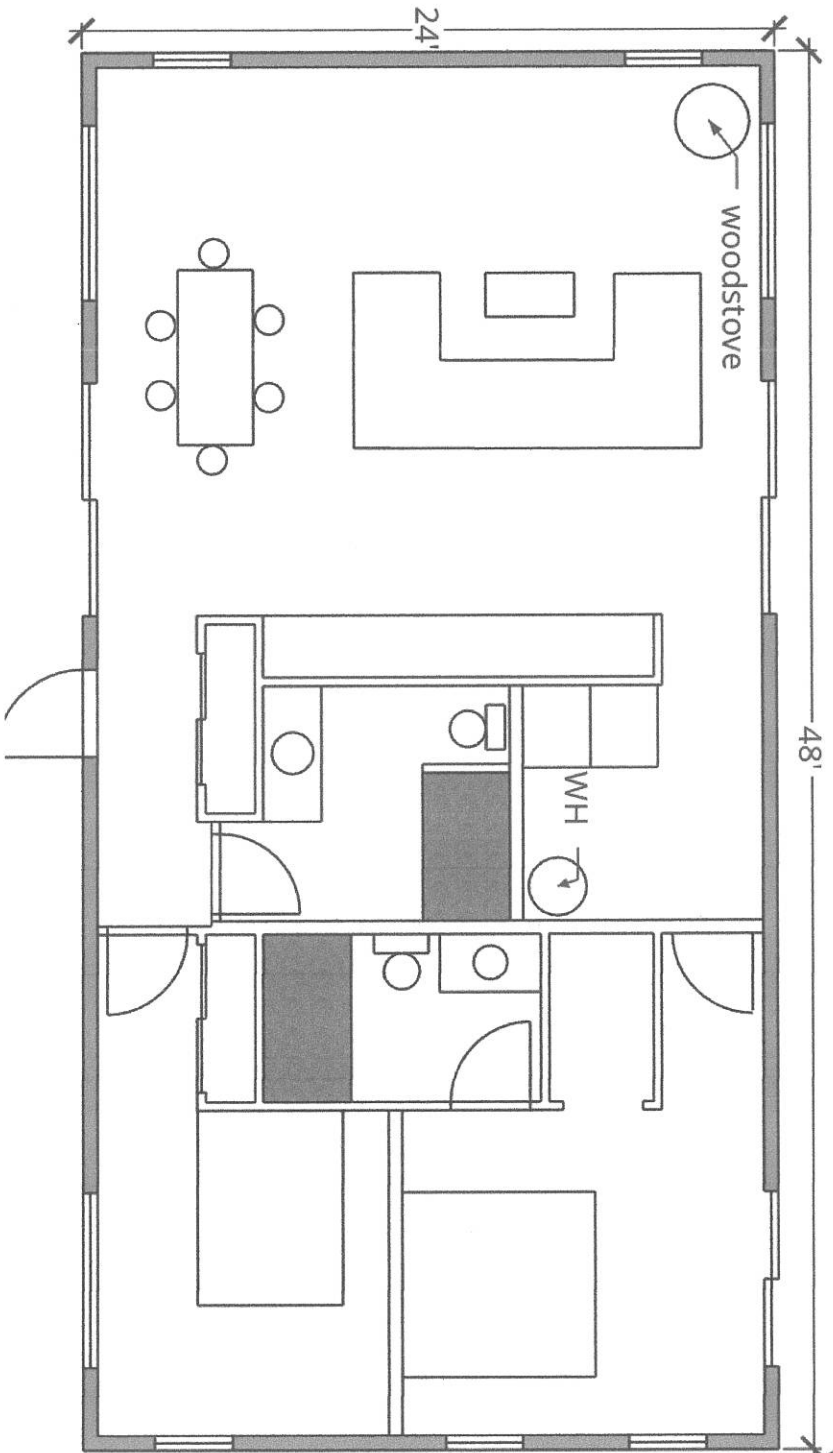



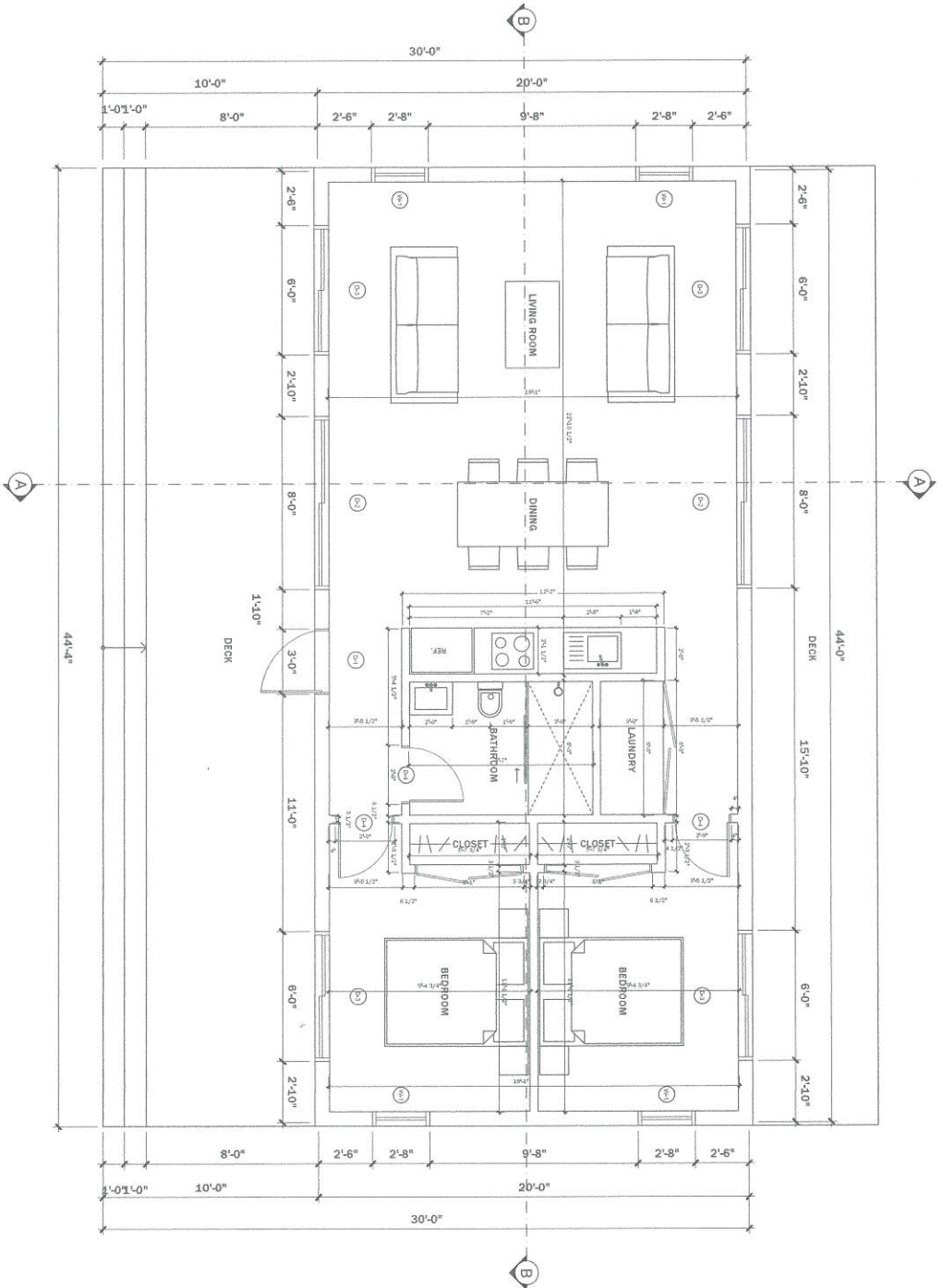

**FLOOR PLAN**  
SCALE: 1/4" = 1'-0"



Contact: [ibrainhouseplans@gmail.com](mailto:ibrainhouseplans@gmail.com)

**Project:**  
**MODERN CABIN HOUSE**

**General Note:**  
1-) ALL DIMENSIONS IN THE DRAWINGS ARE FRAME TO FRAME. FINISHING MATERIALS ARE NOT INCLUDED IN THESE DIMENSIONS. YOU CAN FIND THE DIMENSIONS ON THE "DETAIL DRAWINGS" PAGE.  
2-) CONSULT LOCAL AUTHORITIES AND YOUR CONTRACTORS BEFORE CREATING THIS PLAN. THE ENTIRE RESPONSIBILITY FOR THE CONSTRUCTION OF THIS PROJECT IS YOUR AND YOUR CONTRACTOR(S).  
3-) THE PLANS ARE COPYRIGHTED BY IBRA HOUSE PLANS, LLC. AND INTENDED FOR PERSONAL USE ONLY. NO COMMERCIAL USE OR DISTRIBUTION ALLOWED.

**Sheet Title:**  
**FLOOR PLAN**

**Scale:**  
1/4" = 1'-0"

**Sheet No.:**  
**A 1.1**

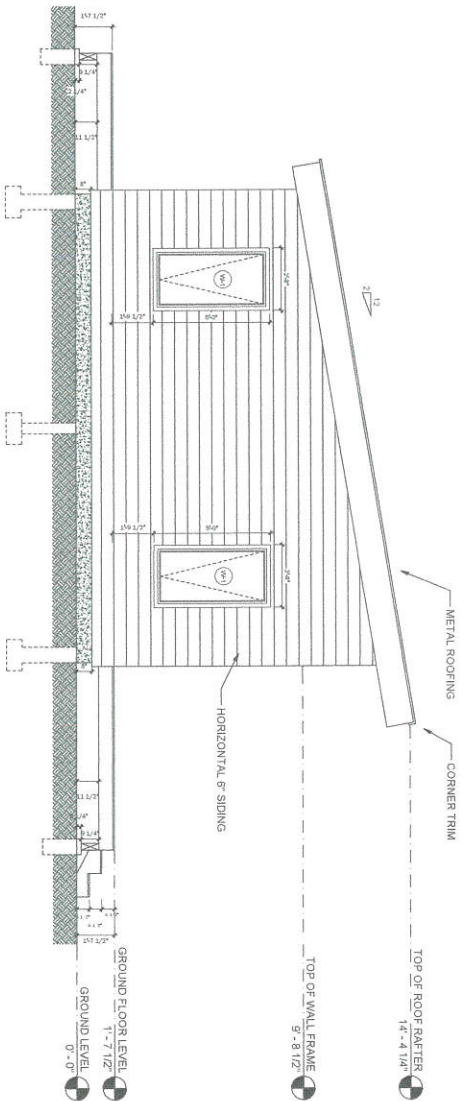

**LEFT SIDE ELEVATION**

SCALE: 1/4" = 1'-0"

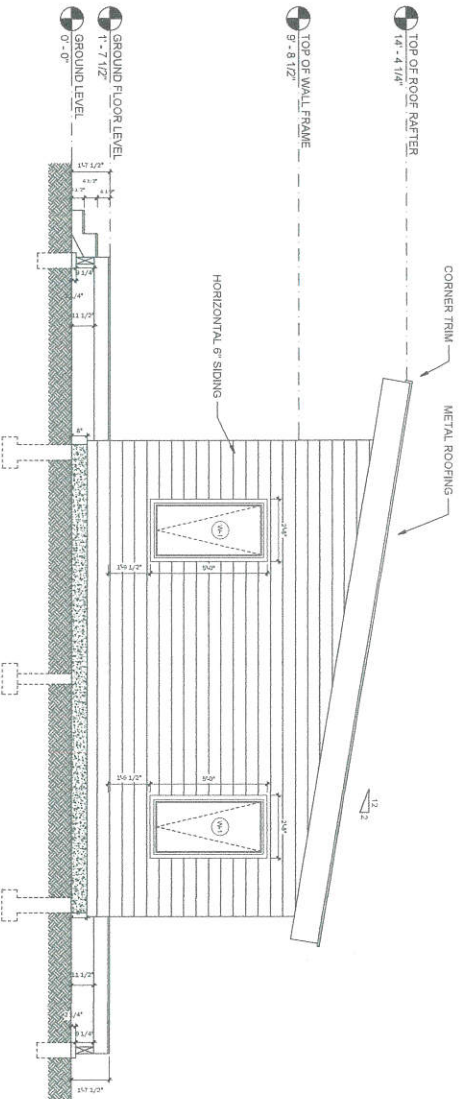

**RIGHT SIDE ELEVATION**

SCALE: 1/4" = 1'-0"

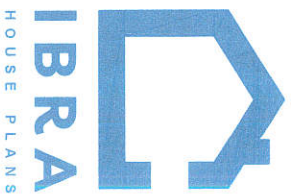

Contact:  
Email: [ibrahouseplans@gmail.com](mailto:ibrahouseplans@gmail.com)

Project:  
**MODERN CABIN HOUSE**

General Note:  
1-) ALL DIMENSIONS IN THE DRAWINGS ARE FRAME TO FRAME. FINISHING MATERIALS ARE NOT INCLUDED IN THESE DIMENSIONS. YOU CAN FIND THE DIMENSIONS ON THE "DETAIL DRAWINGS" PAGE.  
2-) CONSULT LOCAL AUTHORITIES AND YOUR CONTRACTORS BEFORE CREATING THIS PLAN. THE ENTIRE RESPONSIBILITY FOR THE CONSTRUCTION OF THIS PROJECT IS YOUR AND YOUR CONTRACTOR(S).  
3-) THE PLANS ARE COPYRIGHTED BY IBRA HOUSE PLANS, LLC, AND INTENDED FOR PERSONAL USE ONLY. NO COMMERCIAL USE OR DISTRIBUTION ALLOWED.

Sheet Title:  
**ELEVATION DRAWINGS**

Scale:  
**1/4" = 1'-0"**

Sheet No:

**A 2.1**

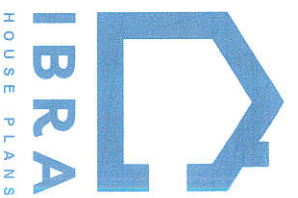

Contact:  
E-mail: [ibrahouseplans@gmail.com](mailto:ibrahouseplans@gmail.com)

Project:  
**MODERN CABIN  
HOUSE**

General Note:  
1-) ALL DIMENSIONS IN THE DRAWINGS ARE FRAME TO FRAME, FINISHING MATERIALS ARE NOT INCLUDED IN THESE DIMENSIONS. YOU CAN FIND THE DIMENSIONS ON THE "DETAIL DRAWINGS" PAGE.  
2-) CONSULT LOCAL AUTHORITIES AND YOUR CONTRACTORS BEFORE CREATING THIS PLAN. THE ENTIRE RESPONSIBILITY FOR THE CONSTRUCTION OF THIS PROJECT IS YOUR AND YOUR CONTRACTOR(S).  
3-) THE PLANS ARE COPYRIGHTED BY IBRA HOUSE PLANS, LLC, AND INTENDED FOR PERSONAL USE ONLY. NO COMMERCIAL USE OR DISTRIBUTION ALLOWED.

Sheet Title:  
**ROOF PLAN**

Scale:  
**1/4" = 1'-0"**

Sheet No.:

**A 4.0**

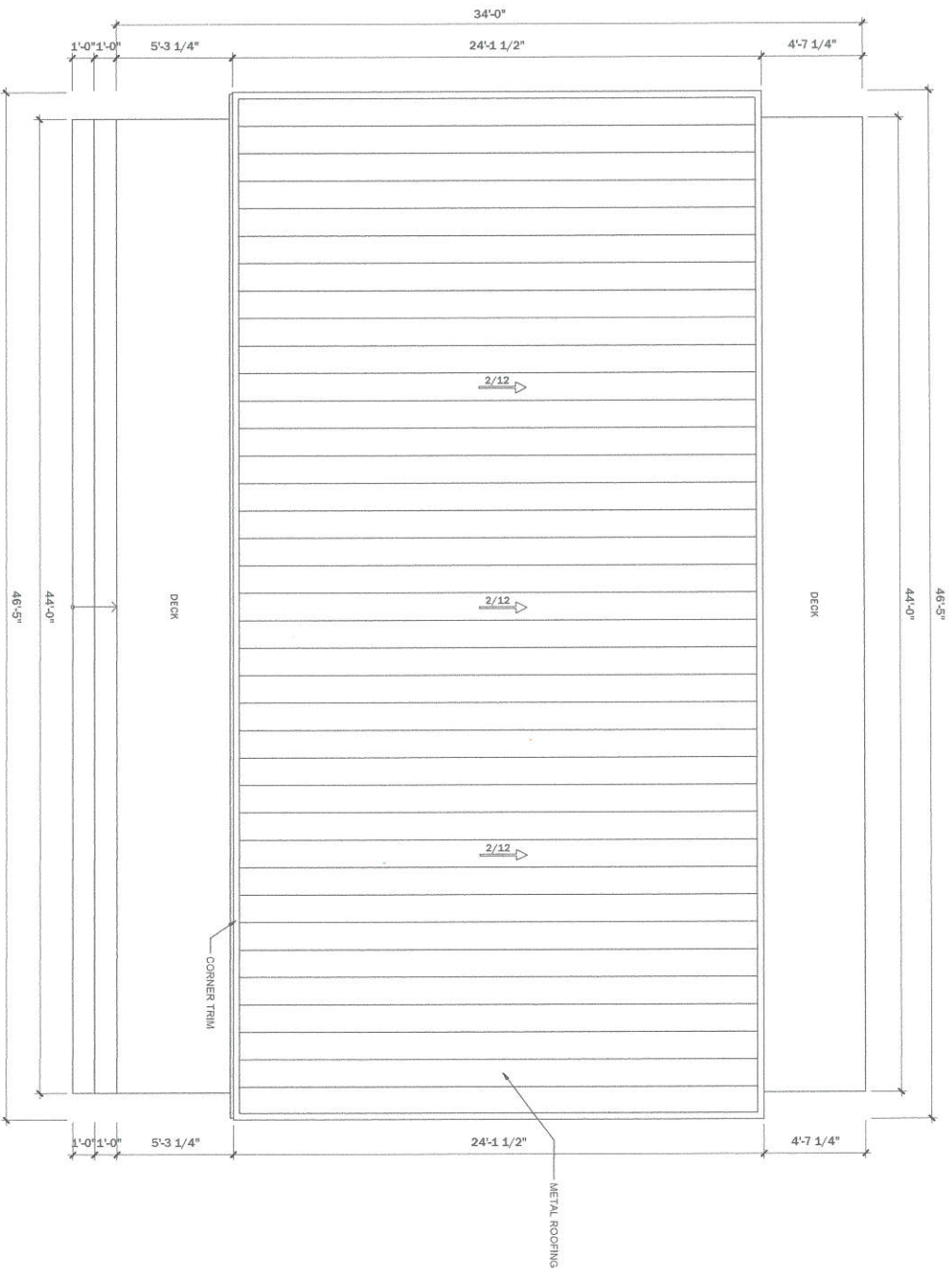

**ROOF PLAN**  
SCALE: 1/4" = 1'-0"



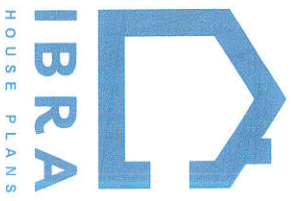

Contact:

Email: [ibrainhouseplans@gmail.com](mailto:ibrainhouseplans@gmail.com)

Project:

MODERN CABIN HOUSE

General Note:

1-) ALL DIMENSIONS IN THE DRAWINGS ARE FRAME TO FRAME. FINISHING MATERIALS ARE NOT INCLUDED IN THESE DIMENSIONS. YOU CAN FIND THE DIMENSIONS ON THE "DETAIL DRAWINGS" PAGE.  
 2-) CONSULT LOCAL AUTHORITIES AND YOUR CONTRACTORS BEFORE CREATING THIS PLAN. THE ENTIRE RESPONSIBILITY FOR THE CONSTRUCTION OF THIS PROJECT IS YOUR AND YOUR CONTRACTOR(S).  
 3-) THE PLANS ARE COPYRIGHTED BY IBRA HOUSE PLANS LLC. AND INTENDED FOR PERSONAL USE ONLY. NO COMMERCIAL USE OR DISTRIBUTION ALLOWED.

Sheet Title:

FOUNDATION PLAN

Scale:

1/4" = 1'-0"

Sheet No.:

A6.0

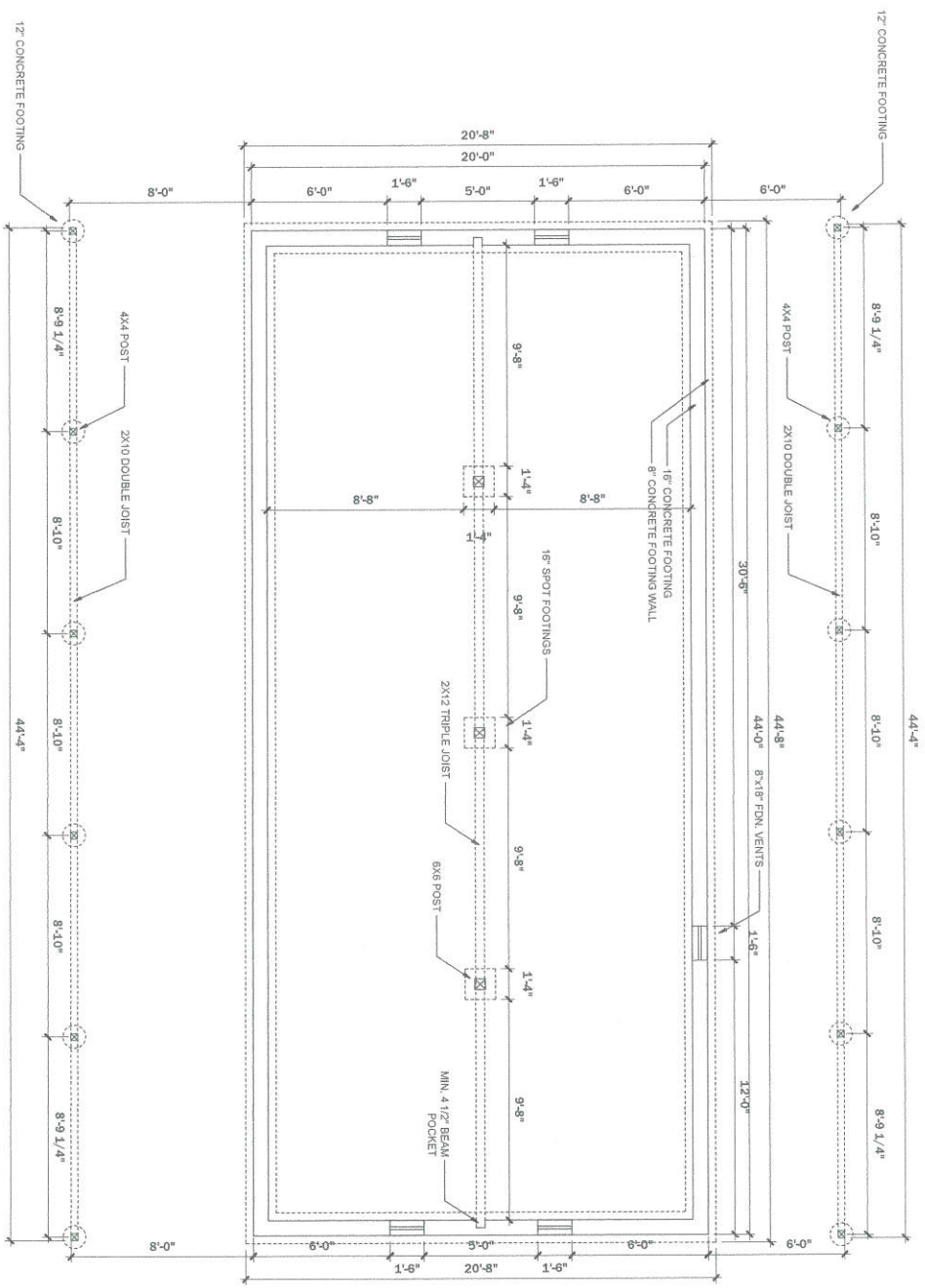

FOUNDATION PLAN  
 SCALE: 1/4" = 1'-0"

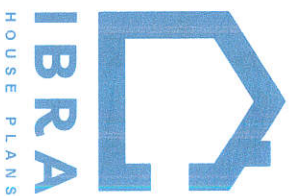

Contact:  
E-mail: [ibrahouseplans@gmail.com](mailto:ibrahouseplans@gmail.com)

Project:  
**MODERN CABIN HOUSE**

General Note:  
1) CONSULT LOCAL AUTHORITIES AND YOUR CONTRACTORS BEFORE CREATING THIS PLAN. THE ENTIRE RESPONSIBILITY FOR THE CONSTRUCTION OF THIS PROJECT IS YOUR AND YOUR CONTRACTOR(S).  
2) THE PLANS ARE COPYRIGHTED BY IBRA HOUSE PLANS LLC. AND INTENDED FOR PERSONAL USE ONLY. NO COMMERCIAL USE OR DISTRIBUTION ALLOWED.

Sheet Title:  
**ELECTRICAL PLAN**

Scale:  
**1/4" = 1'-0"**

Sheet No:  
**A 8.0**

### LEGEND

2D SYMBOL	DESCRIPTION	COMMENTS
	DUPLEX RECEPTACLE OUTLET	
	RECESSED DOWN LIGHT	
	PENDANT LIGHT	
	SINGLE POLE	
	WALL LAMP	

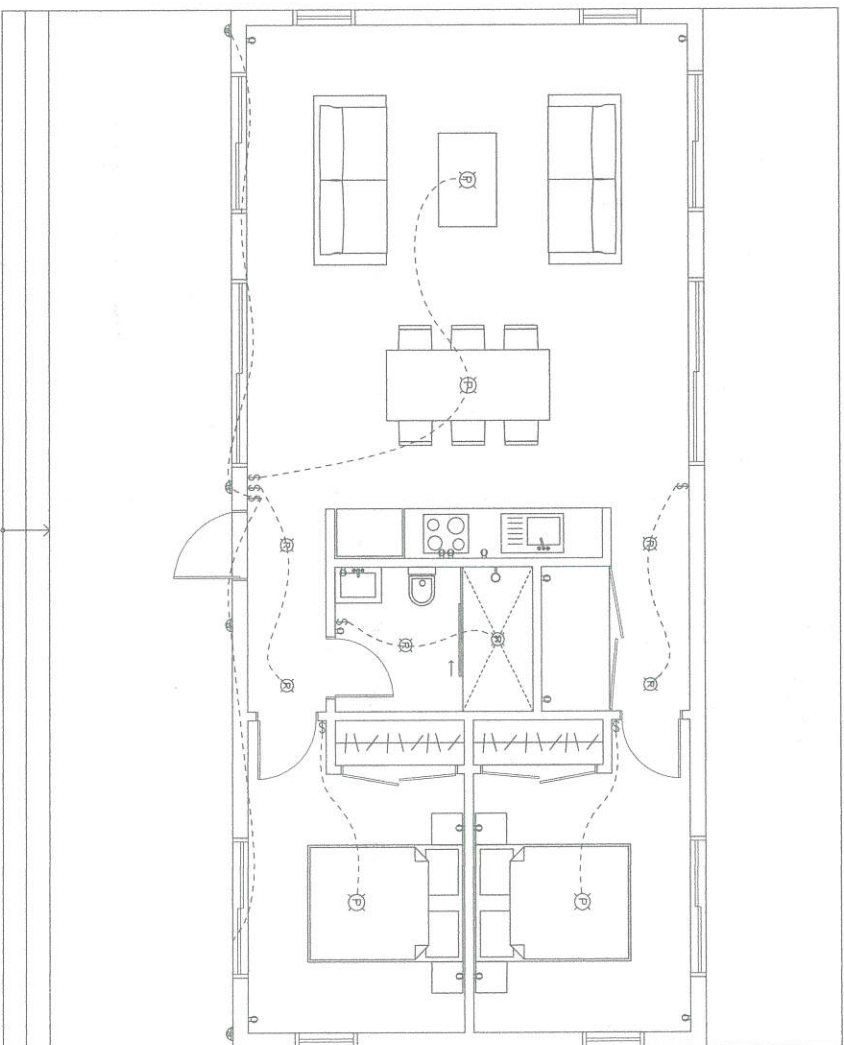

### ELECTRICAL PLAN

SCALE: 1/4" = 1'-0"

**IMPORTANT NOTE:**

1-) ROUGH OPENING DIMENSIONS ARE NO INCLUDED IN WINDOW AND DOOR DIMENSIONS. BECAUSE THERE MAY BE DIFFERENCES BETWEEN THE WINDOW & DOOR BRANDS YOU WILL PURCHASE.

2-) THIS MEANS ADDING 2" OR 2 1/2" (USUALLY THESE DIMENSIONS) TO THE WIDTH AND LENGTH OF THE FRAME OF YOUR WINDOW AND DOOR. PLEASE REMEMBER THESE WHEN FRAMING. AND CHECK THE ROUGH OPENING DIMENSIONS FROM THE BRAND YOU PURCHASED.

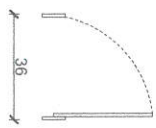
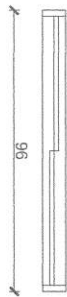
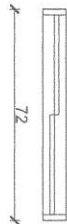
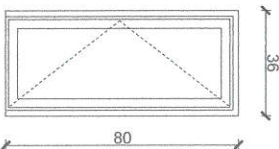
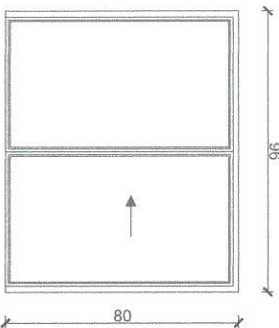
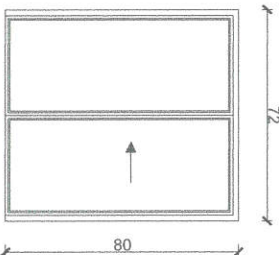
<b>NAME:</b>	D-1	D-2	D-3
<b>QUANTITY:</b>	1	2	4
<b>W x H SIZE:</b>			
<b>2D SYMBOL</b>			
<b>2D FRONT VIEW</b>			

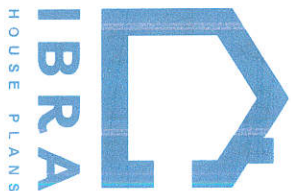

**Contact:**  
E-mail: [ibrainhouseplans@gmail.com](mailto:ibrainhouseplans@gmail.com)

**Project:**  
MODERN CABIN HOUSE

**General Note:**  
1-)CONSULT LOCAL AUTHORITIES AND YOUR CONTRACTORS BEFORE CREATING THIS PLAN. THE ENTIRE RESPONSIBILITY FOR THE CONSTRUCTION OF THIS PROJECT IS YOUR AND YOUR CONTRACTOR(S).

2-) THE PLANS ARE COPYRIGHTED BY IBRA HOUSE PLANS LLC, AND INTENDED FOR PERSONAL USE ONLY. NO COMMERCIAL USE OR DISTRIBUTION ALLOWED.

**Sheet Title:**  
DOOR & WINDOW SCHEDULE-1

**Scale:**  
1/4" = 1'-0"

**Sheet No.:**



A 10.0



**IMPORTANT NOTE:**

1-) ROUGH OPENING DIMENSIONS ARE NO INCLUDED IN WINDOW AND DOOR DIMENSIONS, BECAUSE THERE MAY BE DIFFERENCES BETWEEN THE WINDOW & DOOR BRANDS YOU WILL PURCHASE.

2-) THIS MEANS ADDING 2" OR 2 1/2" (USUALLY THESE DIMENSIONS) TO THE WIDTH AND LENGTH OF THE FRAME OF YOUR WINDOW AND DOOR. PLEASE REMEMBER THESE WHEN FRAMING, AND CHECK THE ROUGH OPENING DIMENSIONS FROM THE BRAND YOU PURCHASED.

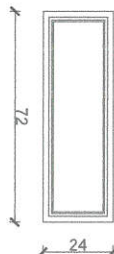
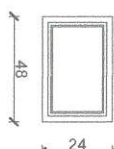
NAME:	W-3	W-4	
QUANTITY:	2	1	
W x H SIZE:			
2D SYMBOL			
2D FRONT VIEW			

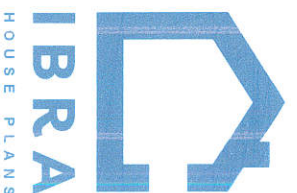

Contact:  
Email: [ibrainhouseplans@gmail.com](mailto:ibrainhouseplans@gmail.com)

Project:  
**MODERN CABIN HOUSE**

General Note:  
1-)CONSULT LOCAL AUTHORITIES AND YOUR CONTRACTORS BEFORE CREATING THIS PLAN, THE ENTIRE RESPONSIBILITY FOR THE CONSTRUCTION OF THIS PROJECT IS YOUR AND YOUR CONTRACTOR(S).

2-) THE PLANS ARE COPYRIGHTED BY IBRA HOUSE PLANS LLC, AND INTENDED FOR PERSONAL USE ONLY. NO COMMERCIAL USE OR DISTRIBUTION ALLOWED.

Sheet Title:  
**DOOR & WINDOW SCHEDULE-2**

Scale:  
1/4" = 1'-0"

Sheet No:

**A 10.2**